

2003 Fact Book



TABLE OF CONTENTS

A Brief History of Meharry Medical College	3
The Board of Trustees	4
Senior Staff	5
Meharry Mission Statement	6
Meharry Vision	7
Meharry Values	8
Degrees Offered	9
Meharry Presidents	10
Student Applicants	11
Admissions	12
Enrollment	13
Degrees Granted	18
Postgraduate Training	21
Entering Student Tuition and Fees	23
Student Financial Aid	23
Employees	24
Faculty	27
Alumni Physicians	30
Alumni Dentists	33
Ph.D. Alumni	36

A Brief History of Meharry Medical College

Meharry Medical College was founded in 1876, as the Medical Department of Central Tennessee College, to educate freed slaves as health care professionals. Fifty years prior to its formal founding, a family of former slaves befriended sixteen-year-old Ohio farmer Samuel Meharry while traveling through rural Kentucky. Meharry was touched by the kindness and generosity of the desperately poor Black family and vowed to repay his debt of gratitude. In 1876, Meharry and his brothers made a \$30,000 gift toward the establishment of the medical department of Central Tennessee College. The Freedman's Aid Society of the Methodist Episcopal Church and the John F. Slater Fund also were contributors.

In 1915, Meharry separated from Walden University (the successor institution to Central Tennessee College), having received a new charter from the State of Tennessee. It did, however, retain its affiliation with the Methodist Church. In January 1916, bylaws were adopted providing for the governance of the College by an 18-member board of trustees. On that same date, the board appointed Dr. George W. Hubbard as the institution's first president.

In the years following, as Meharry continued to grow, it became necessary for the College to move from its four-story building in south Nashville to its present location on Dr. D. B. Todd Boulevard in north Nashville in 1931. The cost of the facility was \$2 million and was made possible by major gifts from the Edward Harkness Foundation, the Rockefeller Foundation, the Julius Rosenwald Fund and George Eastman of the Kodak Foundation.

From these humble beginnings, the College has become the largest private, historically Black institution in the United States exclusively dedicated to the education of health care professionals and biomedical scientists. Today it includes the Schools of Medicine, Dentistry, Graduate Studies and Research, and Allied Health. It has remained a private institution and their respective accrediting bodies accredit all of the College's schools and academic programs. The College has also continued its relationship with the United Methodist Church, receiving approval by the Church's University Senate and funding from its Black College Fund.

The dental department within the Meharry Medical Department of Central Tennessee College was conceived in 1884. Two years later, the dental course was organized within the department as part of the medical curriculum. This expanded its mission as the first institution in the Deep South to train African American dentists and it was also one of a few in that era to promote the recruitment of women into the profession.

The Board of Trustees

Dr. Frank S. Royal, Sr., Chairman
Dr. T.B. Boyd III, Vice Chairman
Dr. John E. Maupin, Jr., President

Dr. Brandon Barton, Jr.
Dr. Mendee Bull-Ligon
Pastor Kirbyjon Caldwell
Dr. Calvin Calhoun, Sr.
Ms. Emelda M. Cathcart
Mrs. M. Inez Crutchfield
Mr. Richard R. Davis
Dr. Jerome King Del Pino
Mr. Marty G. Dickens
Dr. Spencer Disher
Mr. Eddie D. Evans
Dr. Randall Falk
Mr. John C. Graves
Dr. Bennie J. Goggans
Mr. Aubrey Harwell, Jr.
Dr. Tipkins Hood
Ms. Carmen Hopkins
Dr. Cornelius L. Hopper

Dr. Harold O. Jackson
Dr. Martin D. Jeffries
Mr. Milton H. Jones, Jr.
Dr. Shedrick D. Jones
Mr. Kevin P. Lavender
Dr. Abraham McIntosh
Dr. Claude H. Organ, Jr.
Dr. Beny J. Primm
The Hon. Mary Pruitt
Dr. Edward W. Reed
Mr. Edgar G. Rios
Mr. Ray M. Robinson
Dr. Eugene J. Rogers
Dr. Clay E. Simpson, Jr.
Dr. Neal A. Vanselow
Mr. Henry Earl West
Mr. James E. Williams
Mr. Lorenzo Williams
Dr. Robert L. Williams, Jr.
Dr. Howard C. Willis
Dr. Claud R. Young

Senior Staff

John E. Maupin, Jr., D.D.S.
President

Donnetta S. Butler, M.B.A.
Senior Vice President for Finance and Administration

PonJola Coney, M.D.
Senior Vice President for Health Affairs
and Dean of the School of Medicine

Maria de Fatima Lima, Ph.D.
Dean of the School of Graduate Studies and Research
And Vice President of Research Administration

William B. Butler, D.D.S.
Dean of the School of Dentistry

Kathleen McEnerney, D.A.
Dean of the School of Allied Health Professions

Robert Poole
Vice President for Advancement and College Relations

Leilani Boulware, J.D.
Vice President of Policy and Management

Meharry Mission Statement

Meharry Medical College exists to provide excellent education and training in the health sciences, while placing special emphasis on providing opportunities for African Americans, other ethnic minorities and individuals from disadvantaged backgrounds. The College is committed to the delivery of high quality patient-centered health services, and to the conduct of research that fosters improved health outcomes and the elimination of health disparities.

Meharry Vision

To achieve national recognition as a community focused, quality driven academic health center noted for its:

- Uniquely nurturing, highly effective educational programs
- Preeminence in health disparities research
- Culturally sensitive, evidence-based health services
- Significant contribution to the diversity of the nation's health professions workforce

Meharry Values

We, the Board of Trustees, Faculty, and Staff of Meharry Medical College are committed to and governed by the following core values:

1. **Caring**
Maintaining a nurturing environment that treats all people with compassion, dignity, and respect.
2. **Excellence**
Achieving the highest level of performance in all we do, at all levels of the organization.
3. **Integrity**
Upholding the highest standards of ethical behavior, intellectual honesty, and professional conduct.
4. **Diversity**
Fostering ethnic, intellectual, social, and cultural diversity.
5. **Accountability**
Accepting individual and collective responsibility to safeguard and effectively manage the resources of the College.
6. **Innovation**
Promoting creativity and the development of ideas that stimulate improvements in our intellectual and operational endeavors.
7. **Teamwork**
Encouraging and supporting the collective efforts of colleagues to enhance the quality of our teaching, research, and patient care programs.

Degrees Offered

Schools	Degrees	Disciplines
School of Medicine	Doctor of Medicine	<ul style="list-style-type: none"> • Medicine
School of Dentistry	Doctor of Dental Surgery	<ul style="list-style-type: none"> • Dentistry
School of Graduate Studies and Research	Doctor of Philosophy	<ul style="list-style-type: none"> • Biochemistry • Biomedical Sciences • Microbiology • Pharmacology • Physiology
	Master of Science	<ul style="list-style-type: none"> • Public Health • Microbiology • Clinical Investigation • Biochemistry
School of Allied Health Professions <i>(Jointly administered by Meharry Medical College and Tennessee State University)</i>	Certificate from Meharry Medical College; Associate of Applied Science or Bachelor of Science from Tennessee State University	<ul style="list-style-type: none"> • Dental Hygiene • Health Care Administration and Planning • Medical Technology

Meharry Medical College also offers postgraduate training in medicine (family medicine, internal medicine, preventive medicine, psychiatry, and occupational medicine), dentistry (general dentistry and oral-maxillofacial surgery) and postgraduate fellowships.

**Sources: Meharry Medical College Website as of November 2003
Tennessee State University Website as of November 2003**

Meharry Presidents

Name of President	Year Appointed
Dr. John E. Maupin, Jr. <i>(First Meharry graduate to become president)</i>	1993
Dr. David Satcher	1982
Dr. Richard Lester (Interim)	1981
Dr. Lloyd Elam	1968
Dr. Harold D. West <i>(First African-American to become president)</i>	1952
Dr. M.D. Clawson	1945
Dr. Edward L. Turner	1938
Dr. John J. Mallowney	1921
Dr. George W. Hubbard	1876

Source: Tennessee State University Digital Library
(<http://www.tnstate.edu/library/digital/meharry.htm>)

Student Applicants, Fall 2003

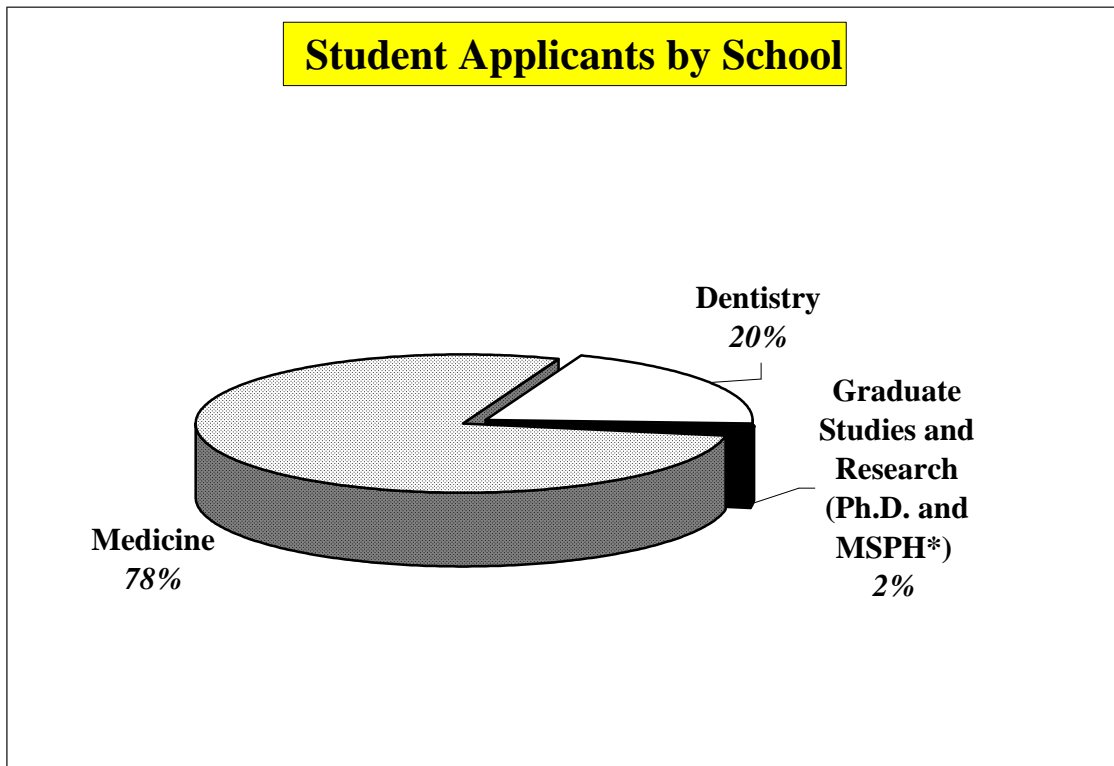

Student Applicants	Number	%
Medicine	3,381	78
Dentistry	878	20
Graduate Studies and Research (Ph.D.)	48	1
Graduate Studies and Research (MSPH*)	44	1
Total	4,351	100

* *Master of Science in Public Health*

Source: Student Information System as of October 2003

Admissions, Fall 2003

Admitted First-Year Students by School

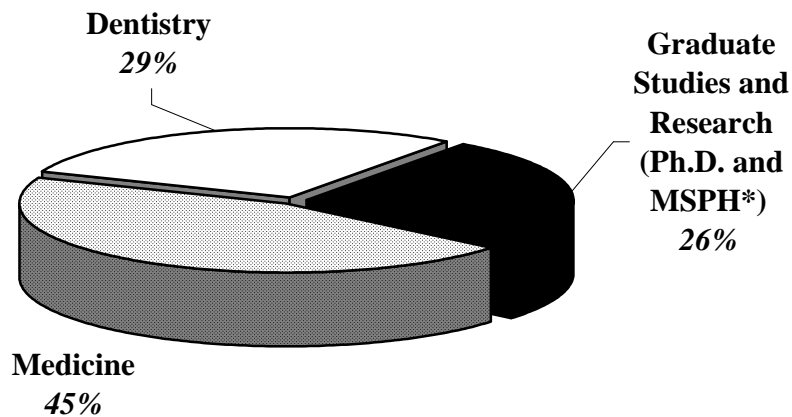

Admitted First-year Students	Number	%
Medicine	80	45
Dentistry	52	29
Graduate Studies and Research (Ph.D.)	19	11
Graduate Studies and Research (MSPH*)	26	15
Total	177	100

* *Master of Science in Public Health*

Source: Student Information System as of October 2003

Enrollment, Fall 2003

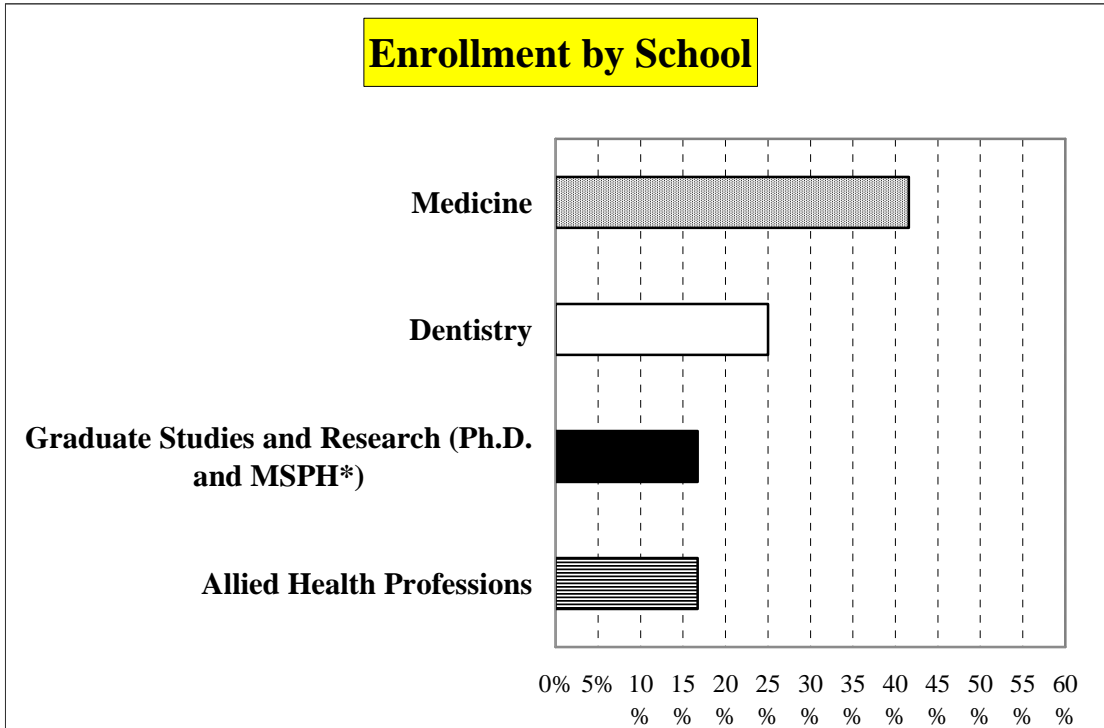

Enrollment by School	Number	%
Medicine	361	42
Dentistry	217	25
Graduate Studies and Research (Ph.D.)	99	11
Graduate Studies and Research (MSPH*)	46	5
Allied Health Professions	145	17
Total	868	100

* *Master of Science in Public Health*

Source: Student Information System as of October 2003

Enrollment, Fall 2003

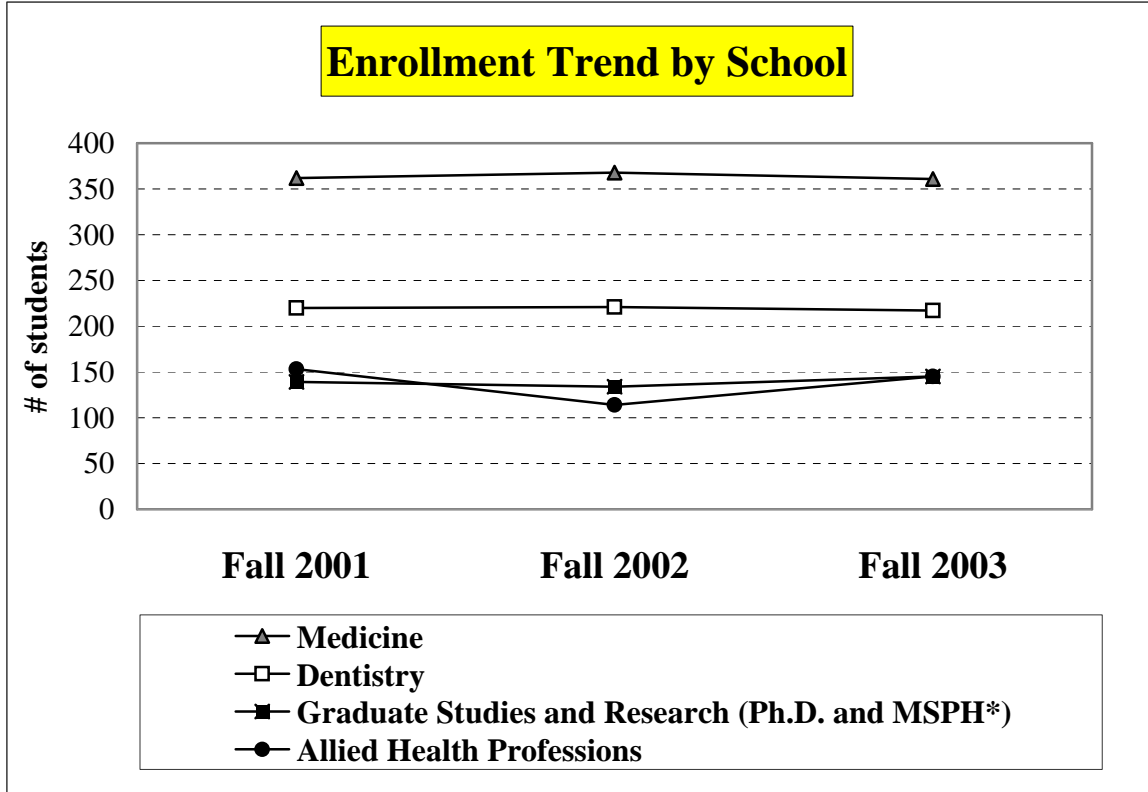

Enrollment Trend	Fall 2001	Fall 2002	Fall 2003
Medicine	362	368	361
Dentistry	220	221	217
Graduate Studies and Research (Ph.D.)	72	75	99
Graduate Studies and Research (MSPH*)	67	59	46
Allied Health Professions	153	114	145
Total	874	837	868

* *Master of Science in Public Health*

Source: Student Information System as of October 2003

Enrollment, Fall 2003

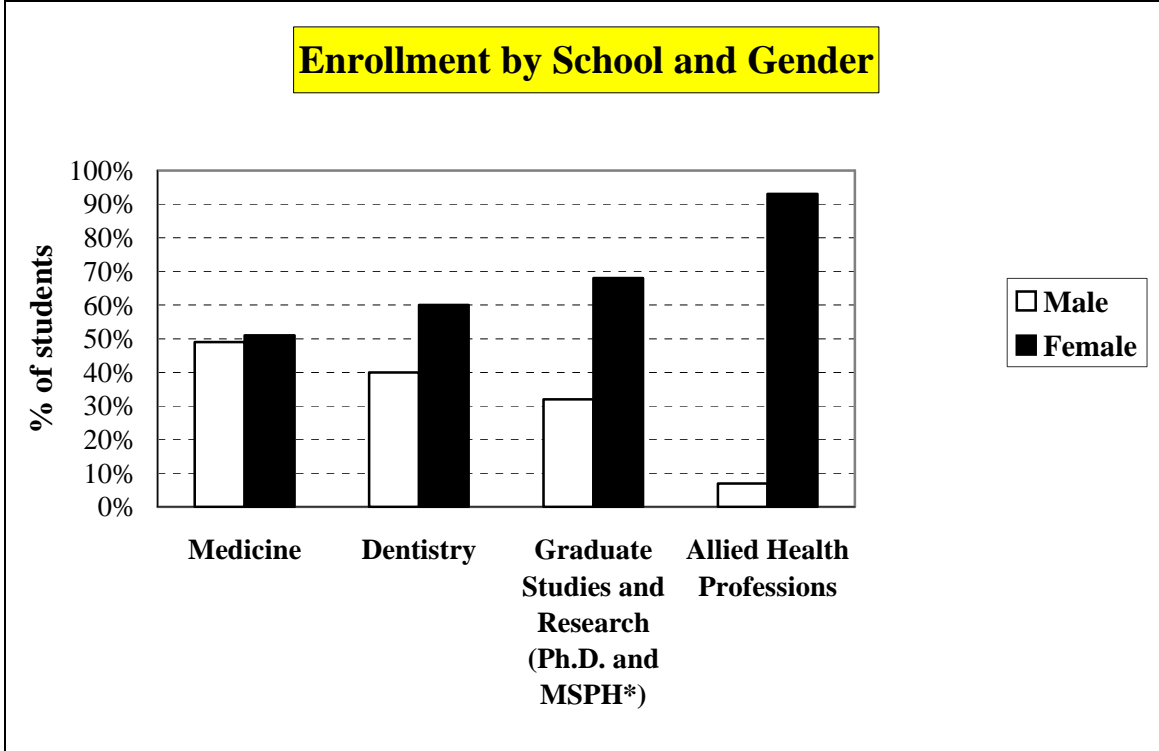

Enrollment by School and Gender	Female	Male
Medicine	184 (51%)	177 (49%)
Dentistry	131 (60%)	86 (40%)
Graduate Studies and Research (Ph.D.)	67 (68%)	32 (32%)
Graduate Studies and Research (MSPH*)	32 (70%)	14 (30%)
Allied Health Professions	135 (93%)	10 (7%)
Total	549 (63%)	319 (37%)

* *Master of Science in Public Health*

Source: Student Information System as of October 2003

Enrollment, Fall 2003

Meharry Student Enrollment by Ethnic Origin

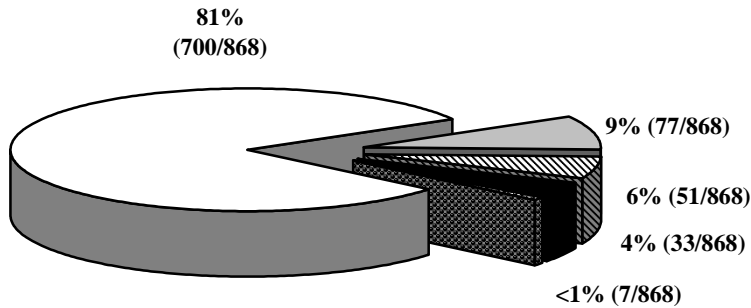

Enrollment by Ethnic Origin	Medicine	Dentistry	Graduate Studies and Research		Allied Health Professions	Total
			(PH.D.)	(MSPH*)		
Black, Non-Hispanic	285 (79%)	182 (84%)	90 (91%)	41 (89%)	102 (70%)	700 (81%)
White, Non-Hispanic	18 (5%)	13 (6%)	4 (4%)	0 (0%)	42 (29%)	77 (9%)
Asian/Pacific Islander	27 (7%)	18 (8%)	3 (3%)	3 (7%)	0 (0%)	51 (6%)
Hispanic	24 (7%)	4 (2%)	2 (2%)	2 (4%)	1 (1%)	33 (4%)
American Indian/Alaskan Native	7 (2%)	0 (0%)	0 (0%)	0 (0%)	0 (0%)	7 (<1%)
Total	361 (100%)	217 (100%)	99 (100%)	46 (100%)	145 (100%)	868 (100%)

* *Master of Science in Public Health*

Source: Student Information System as of October 2003

Enrollment, Fall 2003

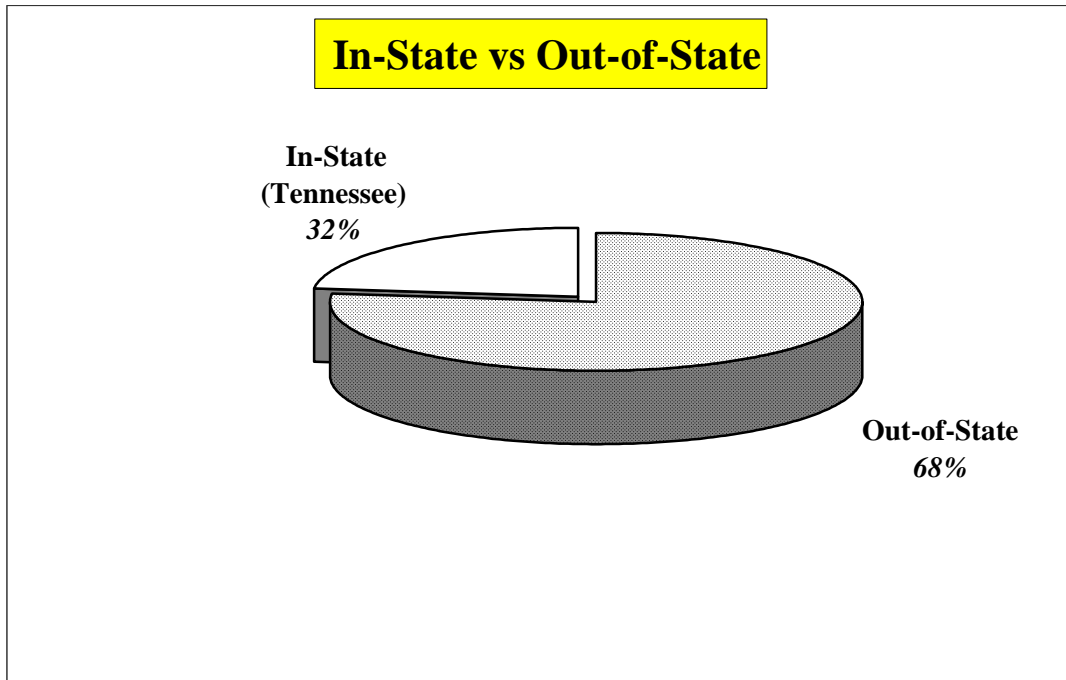

In-State and Out-of-State Enrollment	Number	%
In-State (Tennessee)	280	32
Out-of-State	588	68
Total	868	100

Source: Student Information System as of October 2003

Degrees Granted, Academic Year 2002/2003

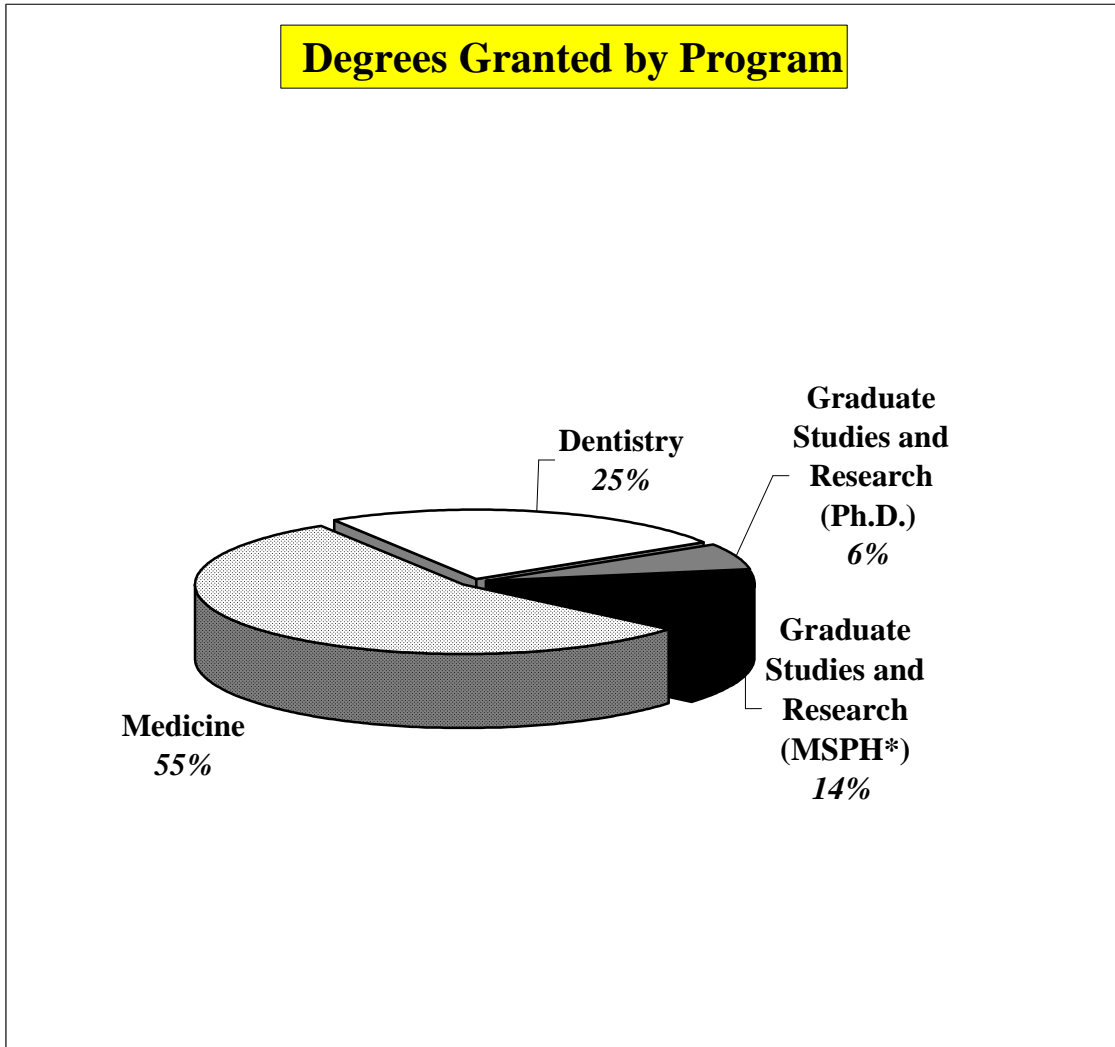

Degrees Granted by Program	Number	%
Medicine	76	55
Dentistry	34	25
Graduate Studies and Research (Ph.D.)	8	6
Graduate Studies and Research (MSPH*)	19	14
Total	137	100

* *Master of Science in Public Health*

Source: Student Information System as of October 2003

Degrees Granted, Academic Year 2002/2003

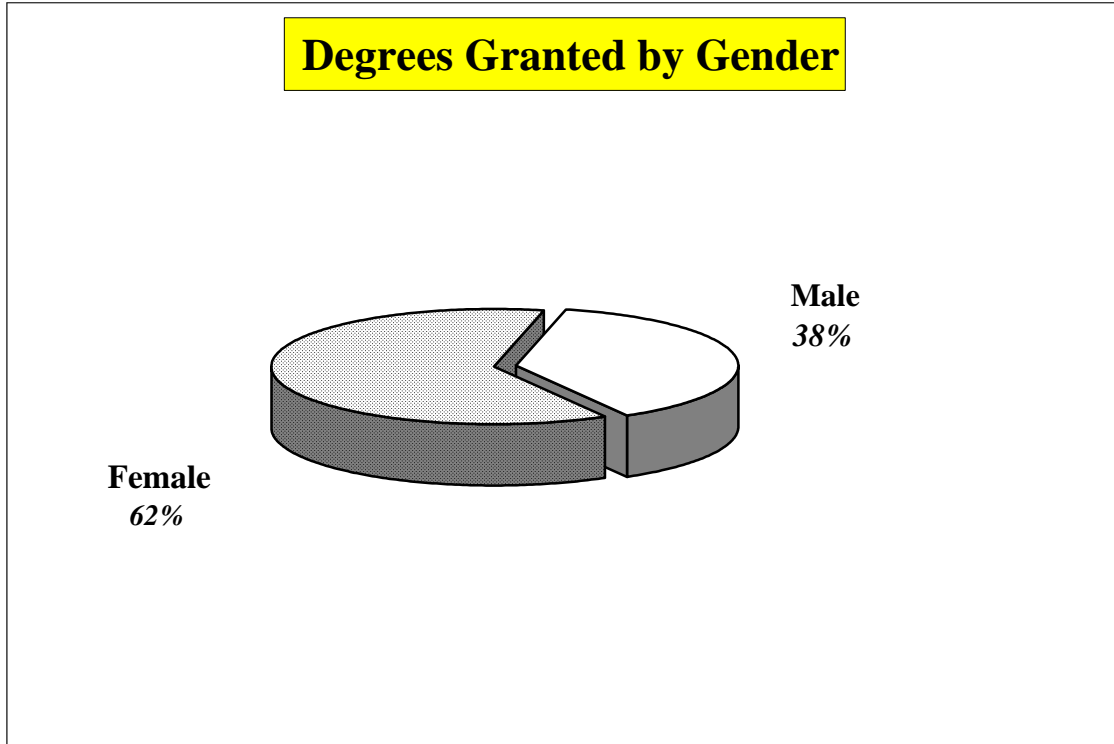

Degrees Granted by Gender	Number	%
Female	85	62
Male	52	38
Total	137	100

Source: Student Information System as of October 2003

Degrees Granted, Academic Year 2002/2003

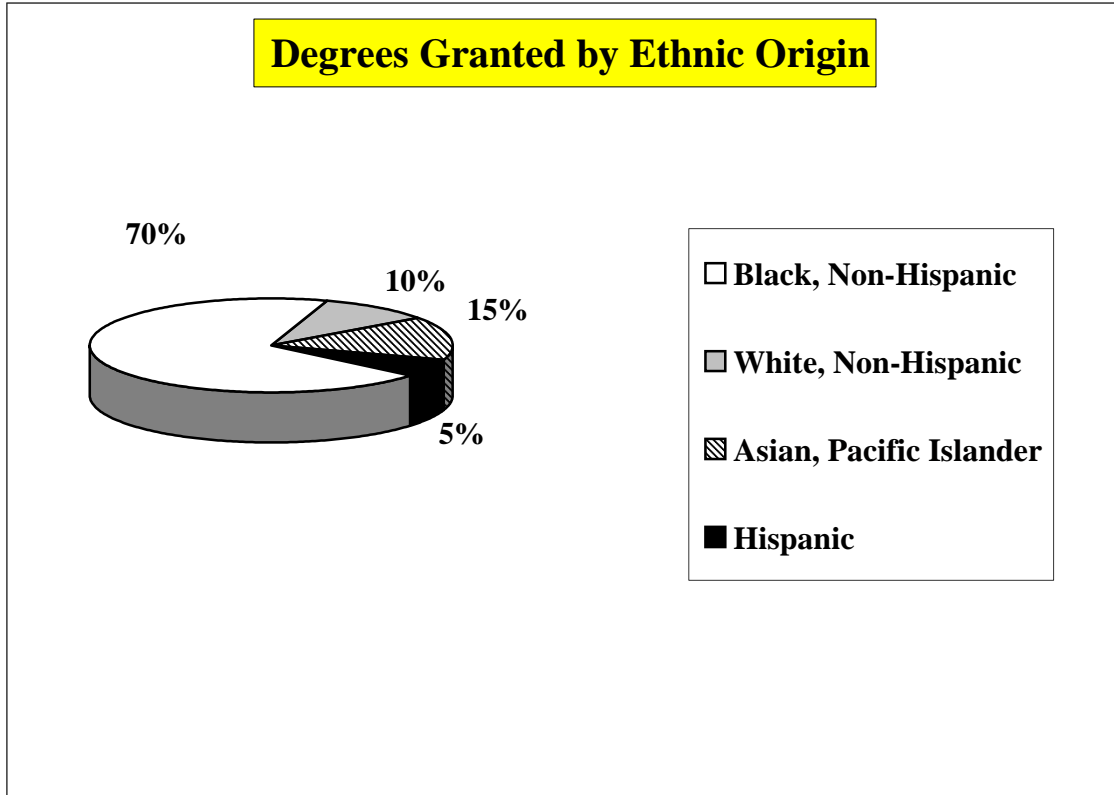

Degrees Granted by Ethnic Origin	Number	%
Black, Non-Hispanic	95	70
White, Non-Hispanic	14	10
Asian/Pacific Islander	21	15
Hispanic	7	5
Total	137	100

Source: Student Information System as of October 2003

Postgraduate Training, 2003

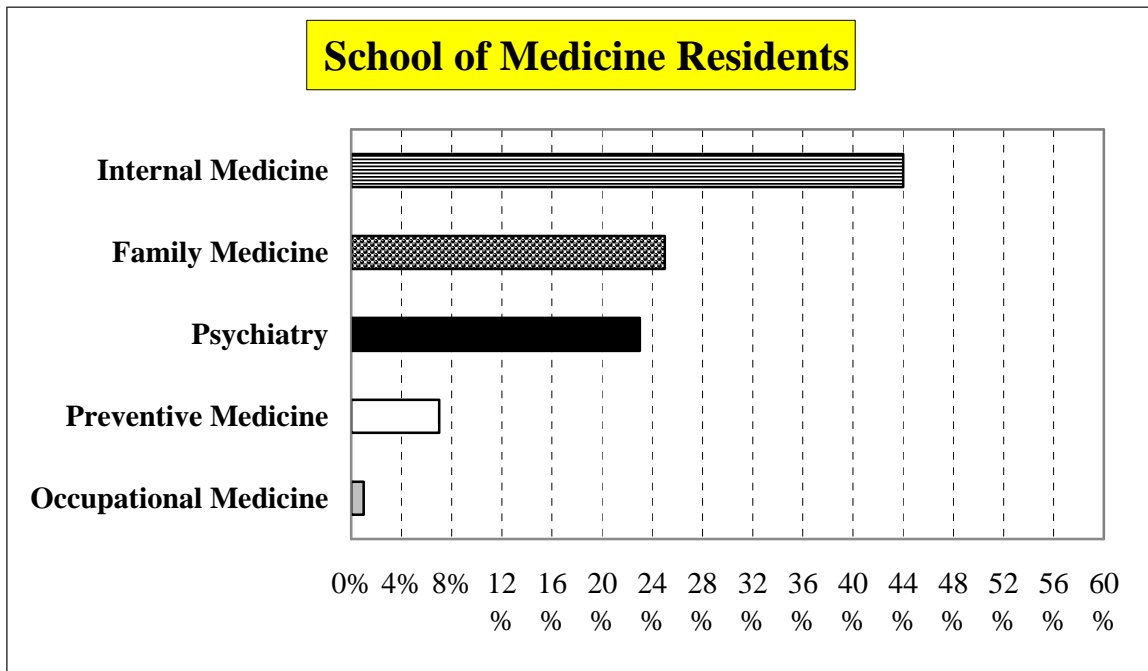

School of Medicine Residents	Number	%
Internal Medicine	34	44
Family Medicine	19	25
Psychiatry	18	23
Preventive Medicine	5	7
Occupational Medicine	1	1
Total	77	100

Source: School of Medicine as of November 2003

Postgraduate Training, 2003

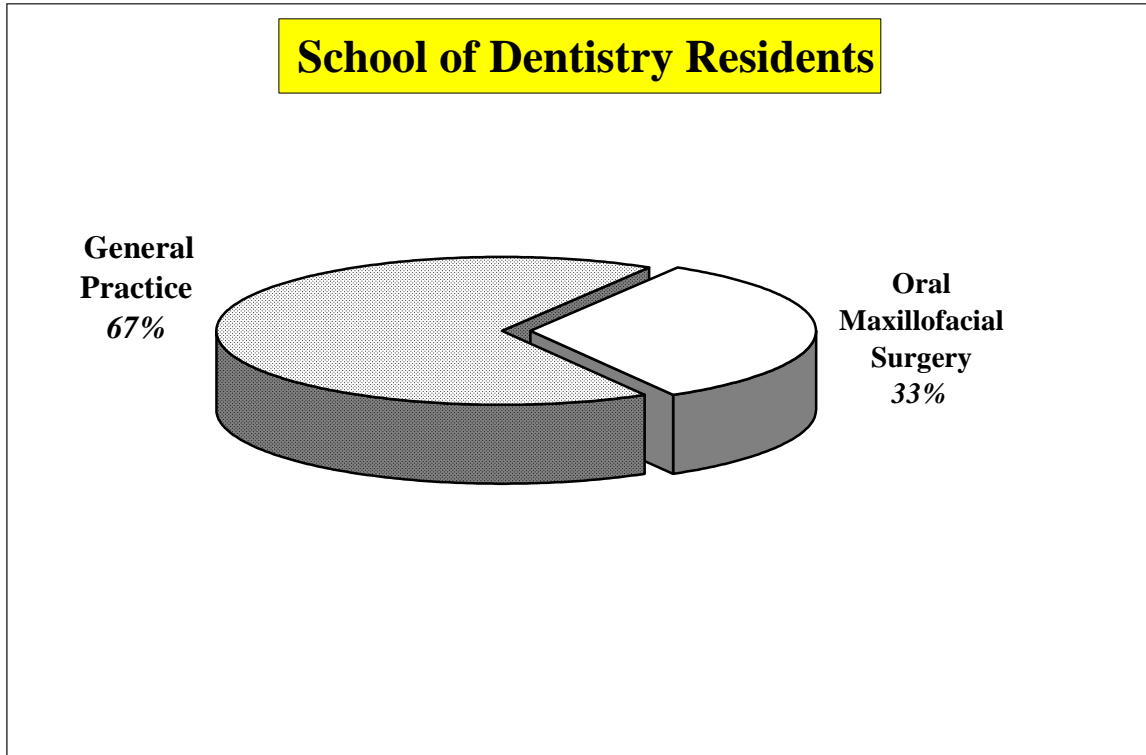

School of Dentistry Residents	Number	%
General Practice	8	67
Oral Maxillofacial Surgery	4	33
Total	12	100

Source: School of Dentistry as of November 2003

Entering Student Tuition and Fees, Academic Year 2003/04

Program	Academic Year 03/04	
		Tuition
Medicine		\$26,352
	Fees	\$5,206
	Total	\$31,558
Dentistry	Tuition	\$26,352
	Fees	\$3,405
	Dental Kit	\$1,312
	Total	\$31,069
Graduate Studies and Research (Ph.D.)	Tuition	\$10,544
	Fees	\$3,053
	Total	\$13,597
Graduate Studies and Research (MSPH*)	Tuition	\$8,477
	Fees	\$2,466
	Total	\$10,943

* *Master of Science in Public Health*

Student Financial Aid, 2003

School	Scholarships/Grants		Loans	
	Amount	# of Students	Amount	# of Students
Medicine	\$1,516,539	168	\$10,159,724	374
Dentistry	\$1,087,497	112	\$6,498,637	239
Graduate Studies and Research	\$31,623	14	\$873,030	63
Total	\$2,635,659	294	\$17,531,391	676

Ninety-three percent (93 %) of medical, dental, and graduate student received financial aid in 2003.

Source: Office of Student Financial Aid

Employees, 2003

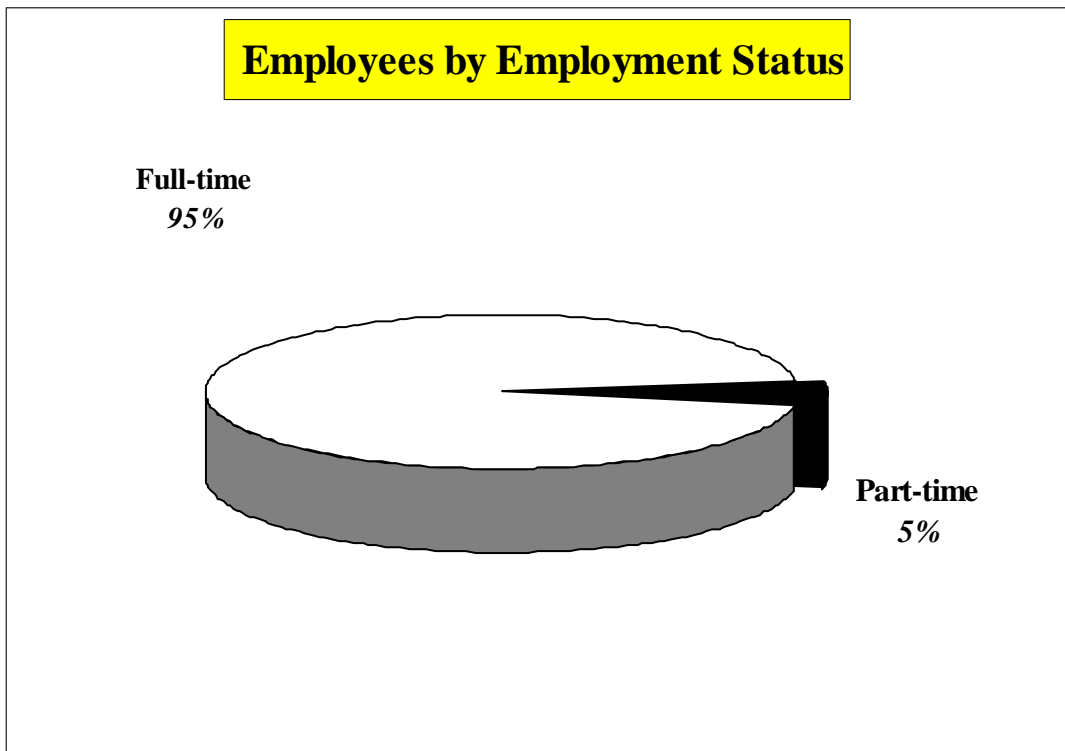

Employees by Employment Status	Number	%
Full-time	921	95
Part-time	52	5
Total	973	100

Source: Human Resources System as of November 1, 2003

Employees, 2003

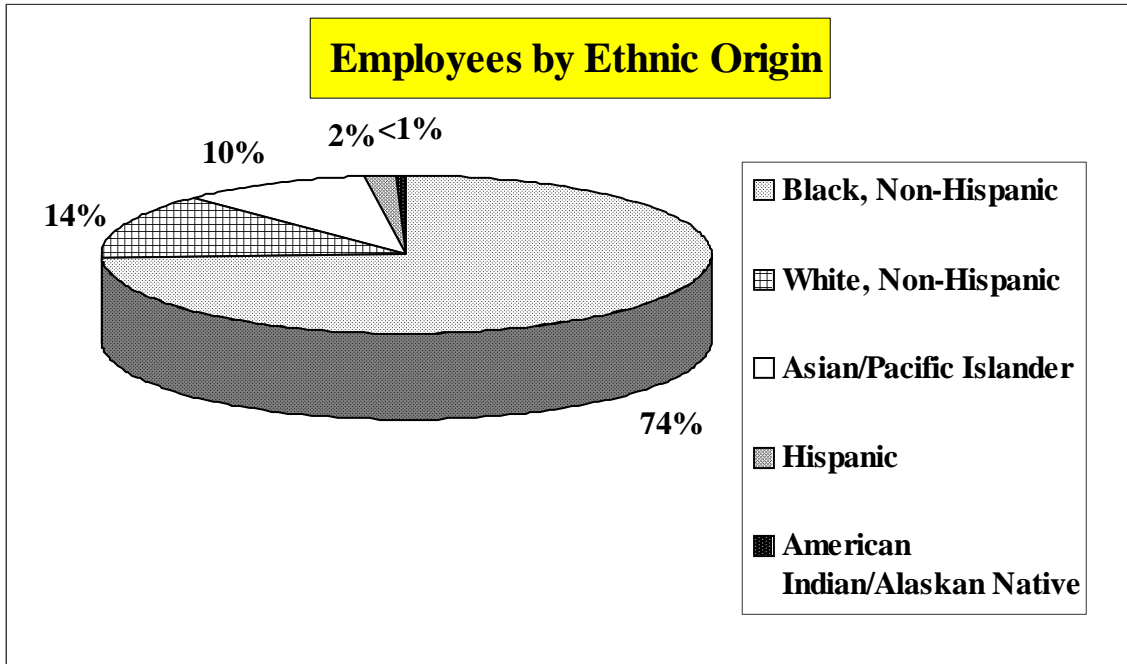

Employees by Ethnic Origin	Number	%
Black, Non-Hispanic	721	74
White, Non-Hispanic	133	14
Asian/Pacific Islander	97	10
Hispanic	16	2
American Indian/Alaskan Native	6	<1
Total	973	100

Source: Human Resources System as of November 1, 2003

Employees, 2003

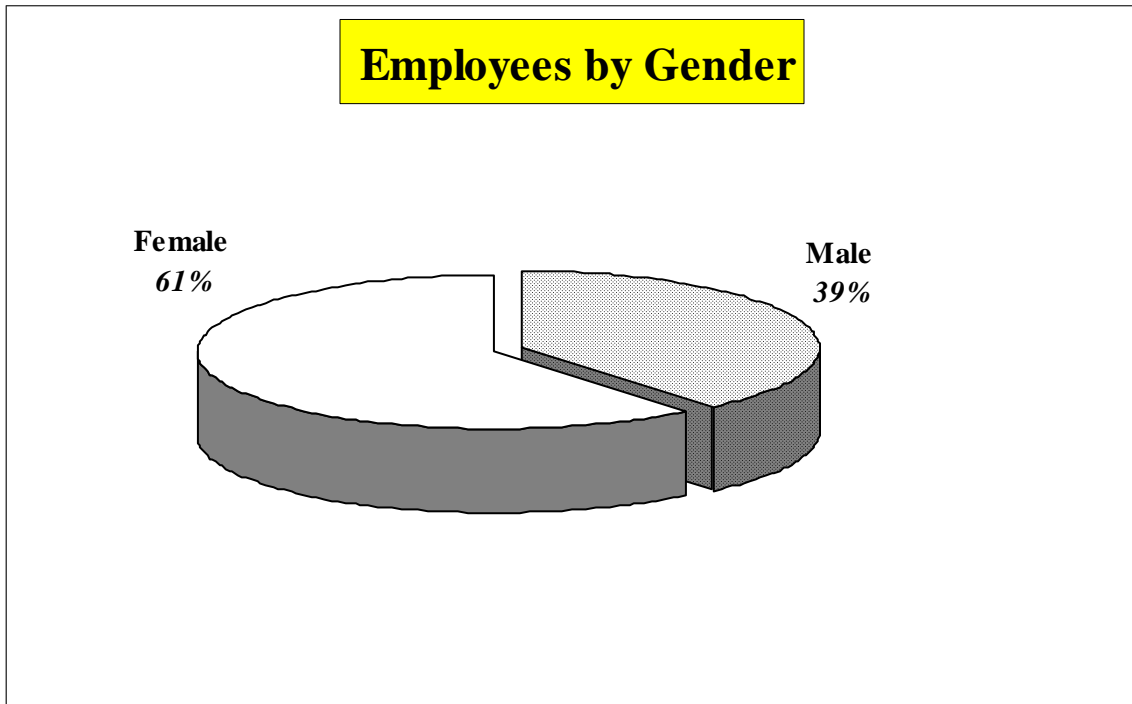

Employees by Gender	Number	%
Female	596	61
Male	377	39
Total	973	100

Source: Human Resources System as of November 1, 2003

Faculty, 2003

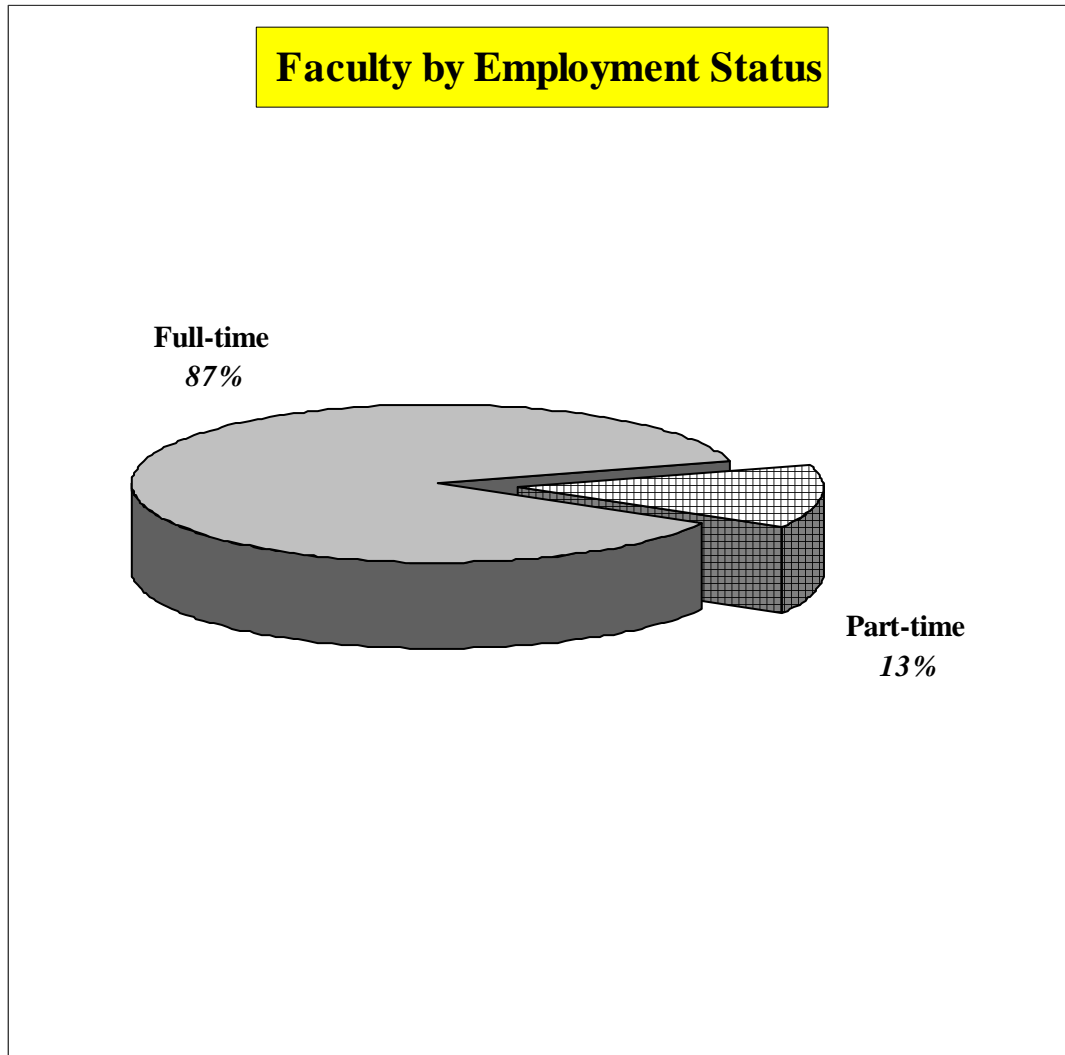

Faculty by Employment Status	Number	%
Full-time	210	87
Part-time	32	13
Total	242	100

Source: Human Resources System (Instructional faculty are counted on the basis of an 11/12 month-salary contract; data are counted as of November 1, 2003)

Faculty, 2003

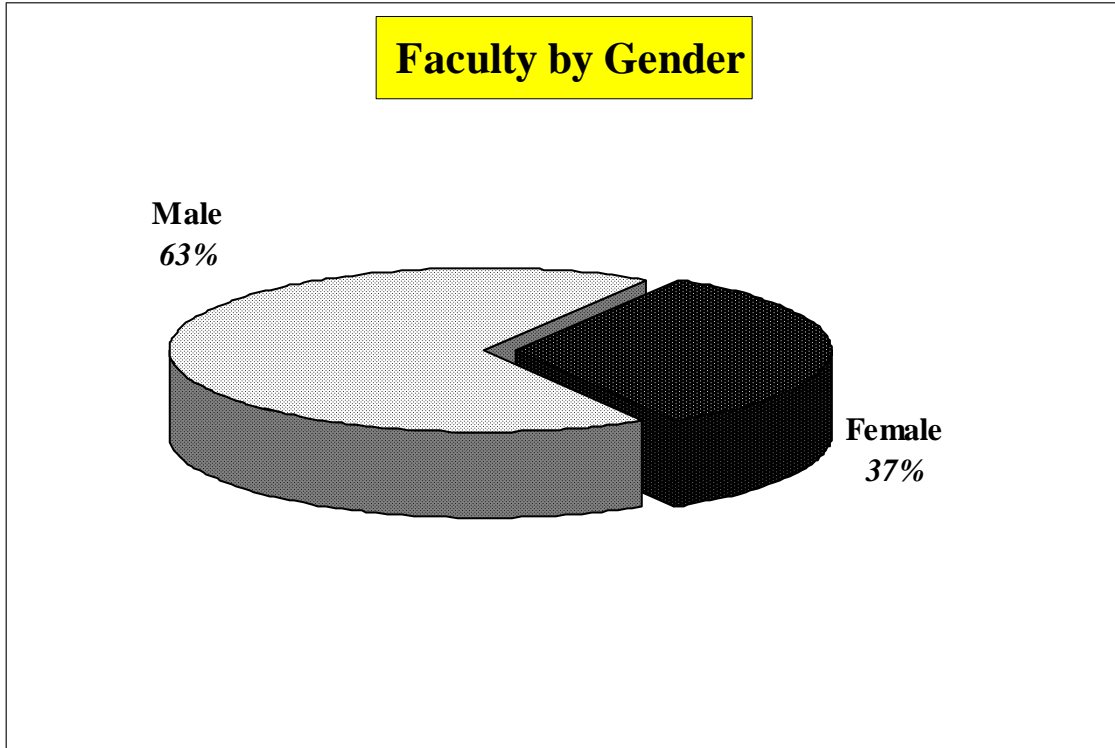

Faculty by Gender	Number	%
Female	90	37
Male	152	63
Total	242	100

Source: Human Resources System (Instructional faculty are counted on the basis of an 11/12 month-salary contract; data are counted as of November 1, 2003)

Faculty, 2003

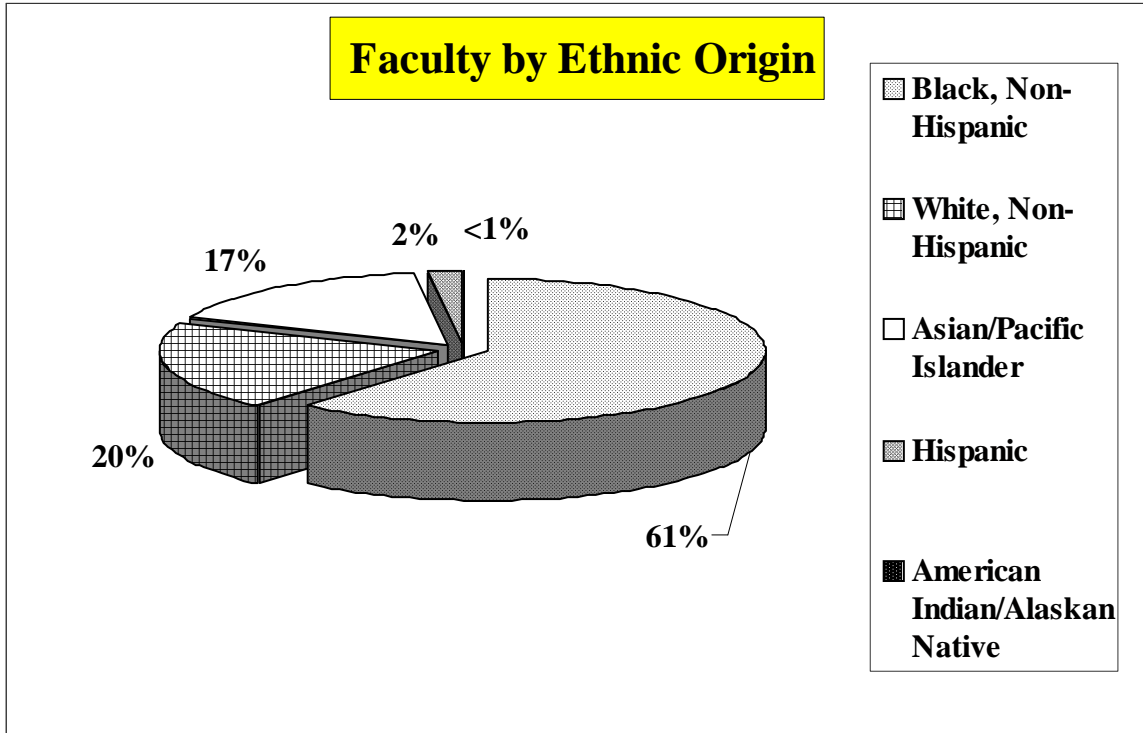

Faculty by Ethnic Origin	Number	%
Black, Non-Hispanic	147	61
White, Non-Hispanic	48	20
Asian/Pacific Islander	40	17
Hispanic	6	2
American Indian/Alaskan Native	1	<1
Total	242	100

Source: Human Resources System (Instructional faculty are counted on the basis of an 11/12 month-salary contract; data are counted as of November 1, 2003)

Alumni Physicians

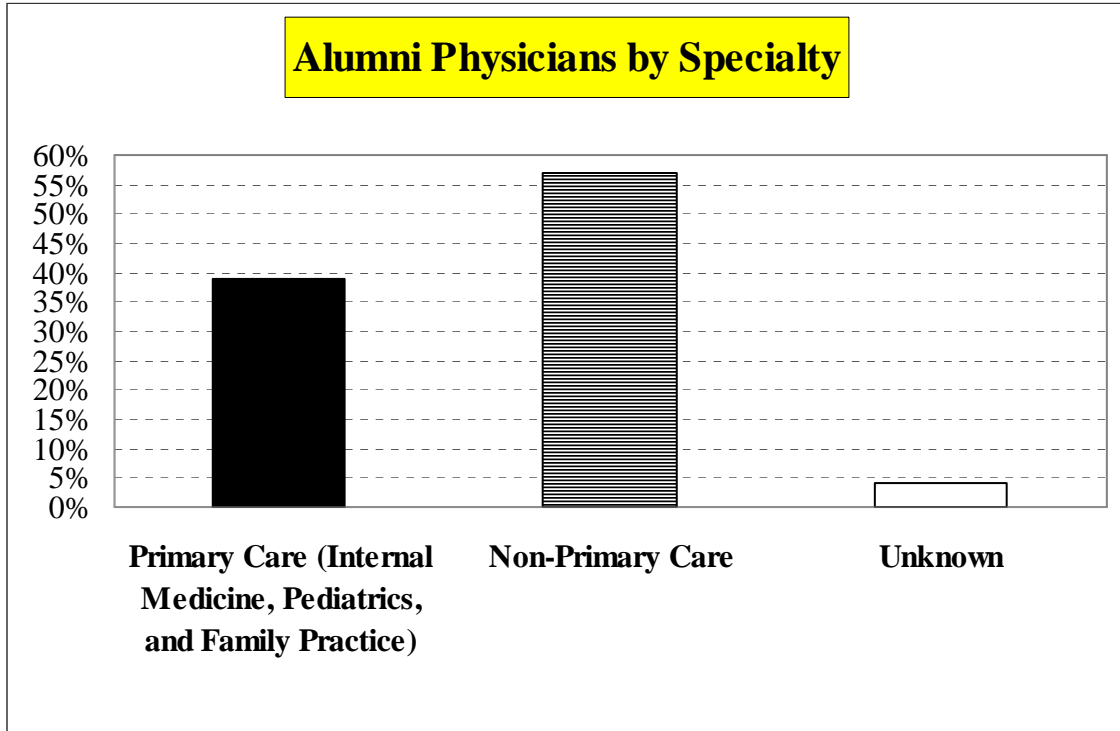

Specialty	Number	%
Primary Care (Internal Medicine, Pediatrics, and Family Practice)	1,482	39
Non-Primary Care	2,173	57
Unknown	159	4
Total	3,814	100

Source: American Medical Association as of December 2003

Alumni Physicians

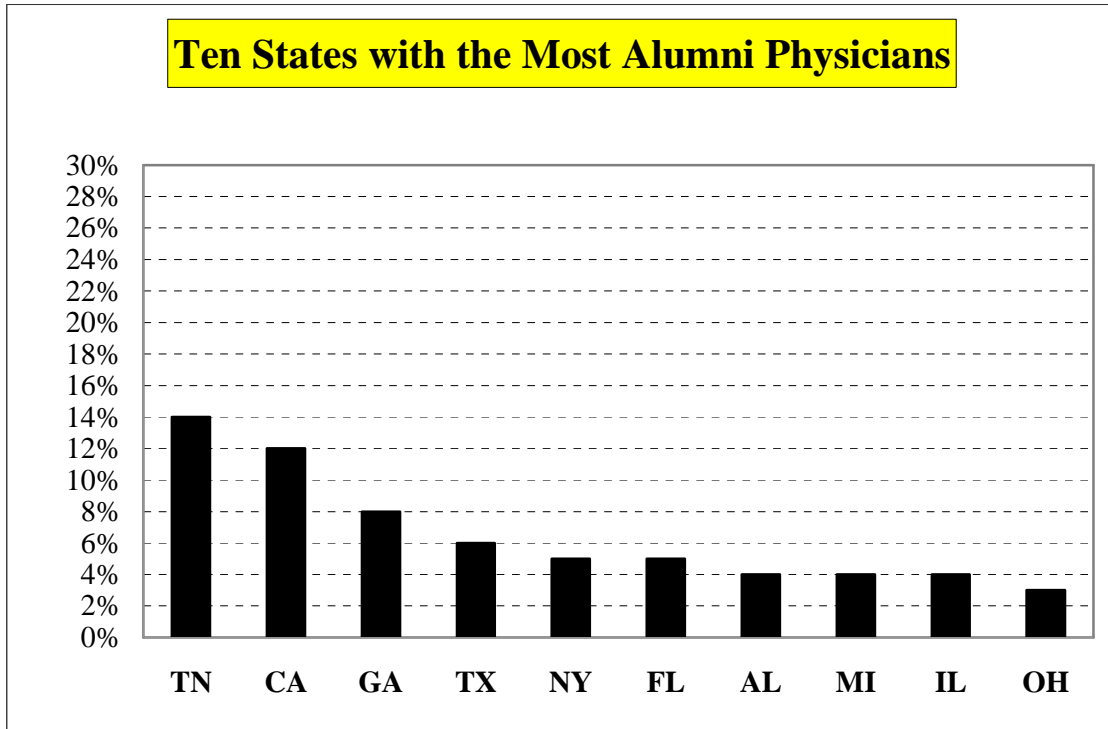

Ten States with the Most Alumni Physicians	Number	%
Tennessee (TN)	541	14
California (CA)	473	12
Georgia (GA)	287	8
Texas (TX)	229	6
New York (NY)	191	5
Florida (FL)	174	5
Alabama (AL)	152	4
Michigan (MI)	146	4
Illinois (IL)	142	4
Ohio (OH)	136	3
All Other States	1,343	35
Total	3,814	100

Source: American Medical Association as of December 2003

Alumni Physicians

Ten Largest Alumni Physician Specialties

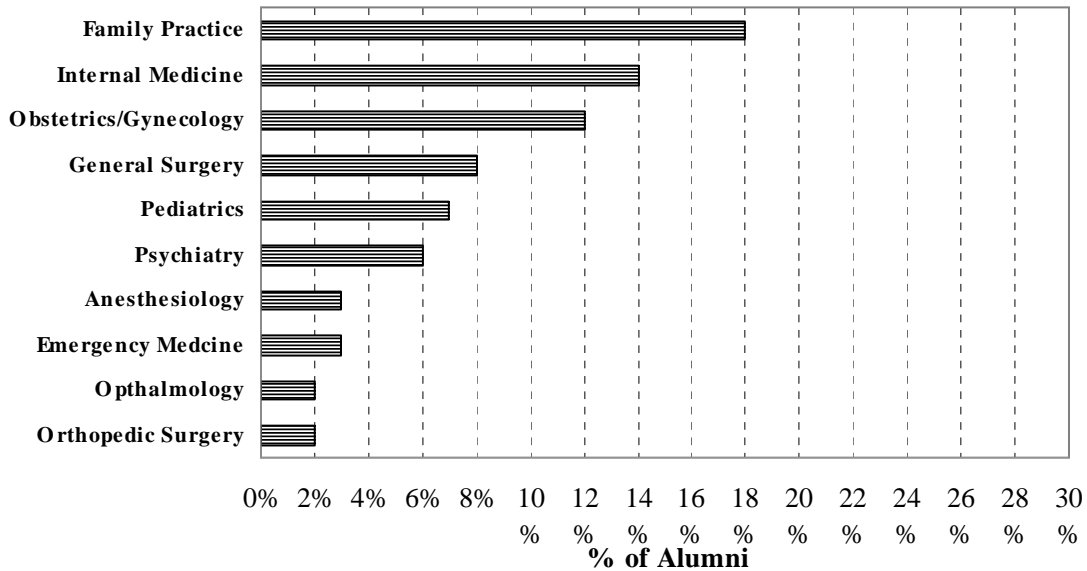

Ten Largest Alumni Physician Specialties	Number	%
Family Practice	689	18
Internal Medicine	531	14
Obstetrics/Gynecology	465	12
General Surgery	295	8
Pediatrics	262	7
Psychiatry	243	6
Anesthesiology	130	3
Emergency Medicine	98	3
Ophthalmology	88	2
Orthopedic Surgery	65	2
All Other Specialties	948	25
Total	3,814	100

Source: American Medical Association as of December 2003

Alumni Dentists

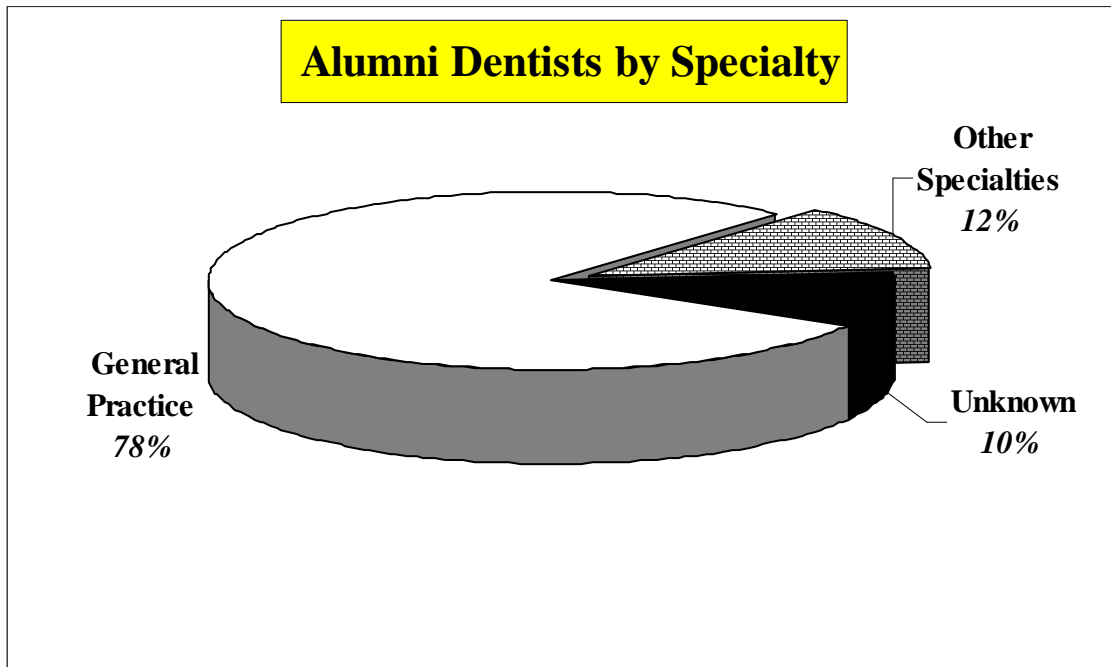

Specialty	Number	%
General Practice	1,343	78
Other Specialties	205	12
Unknown	169	10
Total	1,717	100

Source: American Dental Association as of December 2003

Alumni Dentists

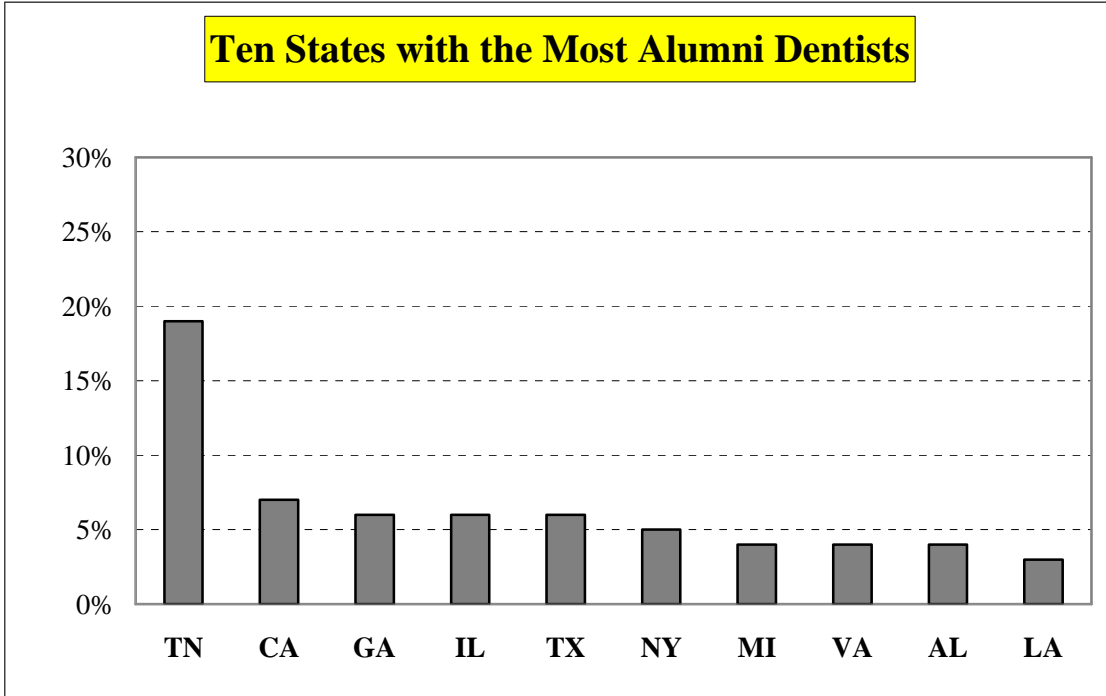

Ten States with the Most Alumni Dentists	Number	%
Tennessee (TN)	299	17
California (CA)	116	7
Georgia (GA)	93	5
Illinois (IL)	92	5
Texas (TX)	88	5
New York (NY)	75	4
Michigan (MI)	71	4
Virginia (VA)	61	4
Alabama (AL)	61	4
Louisiana (LA)	55	3
All Other States	706	41
Total	1,717	100

Source: American Dental Association as of December 2003

Alumni Dentists

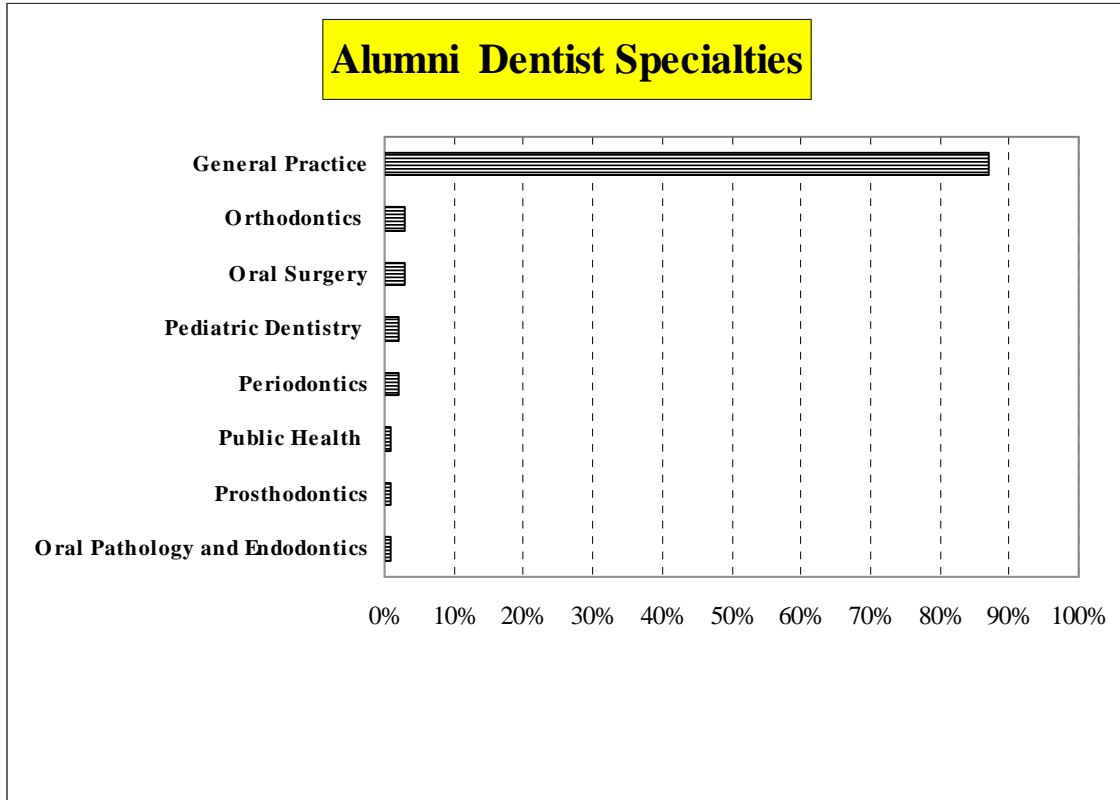

Alumni Dentist Specialties	Number	%
General Practice	1,343	78
Orthodontics	48	3
Oral Surgery	41	2
Pediatric Dentistry	31	2
Periodontics	24	1
Public Health	23	1
Prosthodontics	22	1
Endodontology	11	<1
Oral Pathology	5	<1
Unknown	169	11
Total	1,717	100

Source: American Dental Association as of December 2003

Ph.D. Alumni

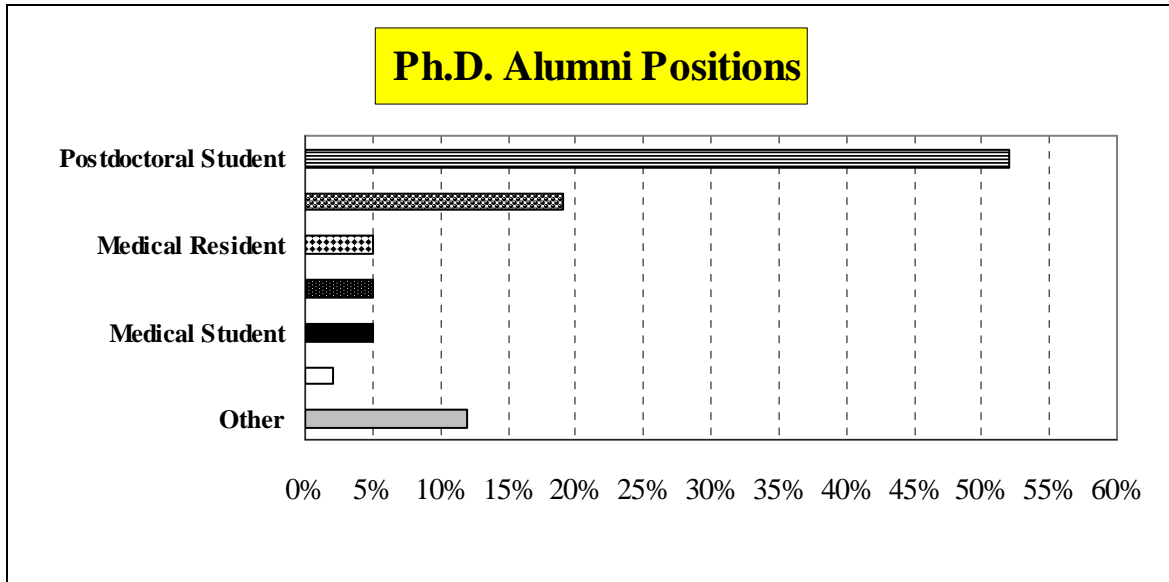

Position	Number	%
Postdoctoral Student	92	52
College Professor	34	19
Medical Resident	8	5
Scientific Researcher	8	5
Medical Student	9	5
College Chairperson	4	2
Other	21	12
Total	176	100

Source: School of Graduate Studies as of December 2003

*Embarking on a New
Era of Achievement*

MEHARRY MEDICAL COLLEGE
1005 Dr. D.B. Todd, Jr. Blvd.
Nashville, Tennessee 37208
(615) 327-6111
www.mmc.edu

PUBLICATION DATE: March 15, 2004